

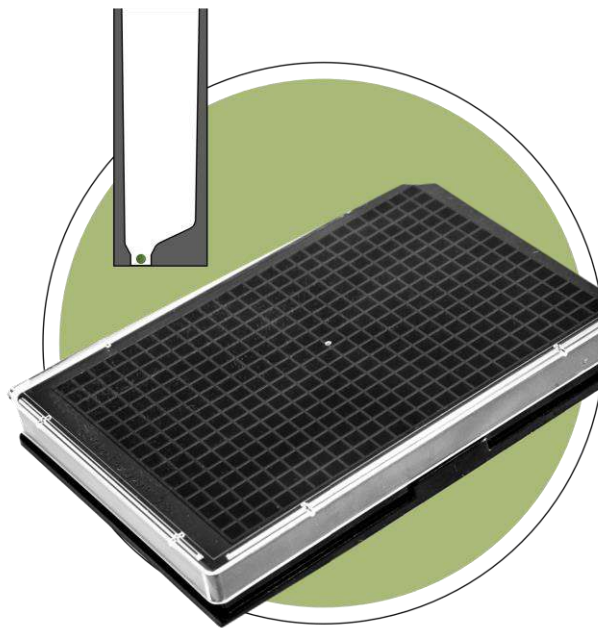

Akura™ 384 Spheroid Microplate **Product Manual**



PM007, June 2023

Contents

Introduction	2
Advantages of Akura™ 384 Spheroid Microplate	2
The Akura™ 384 Spheroid Microplate	3
Akura™ 384 Spheroid Microplate Design	5
Plate orientation for manual pipetting tasks	6
Generating 3D Spheroids	7
Additional Materials Required	7
Preparation	7
Pre-wetting	7
Cell seeding	8
Cell sedimentation and spheroid maturation	8
Medium Exchange in Akura™ 384 Spheroid Microplates	9
Medium exchange with multi-channel electronic pipettes	9
Semi-automated medium exchange with the INTEGRA VIAFLO 96/384 System	10
Analysis and Assays in Akura™ 384 Spheroid Microplate	13
Spheroid Collection and Transfer	15
Annex A: Akura™ 384 Spheroid Microplate Specifications	17
Akura™ 384 Plate restrictions	22
Annex B: License Agreement	23
Annex C: Frequently Asked Questions Regarding the Akura™ 384 Spheroid Microplate	24

Introduction

InSphero Akura™ 384 Spheroid Microplate represents a simple, flexible, and automation-compatible platform for the generation, long-term cultivation, observation and testing of scaffold-free 3D cell cultures in 384-well format. Each plate consists of a special ultra-low attachment (ULA) 384-well, sterile-packaged Akura™ 384 Plate and lid.

InSphero recommends Akura™ 384 Plates for the generation of spheroids using immortalized or modified cell lines as well as primary or iPS-derived cells that are known to readily form spheroids.

The Akura™ 384 Plate is compatible with state-of-the-art imaging and automated liquid handling systems for HTS applications. Biochemical assays can be performed on spheroids directly in Akura™ Plates.

The Akura™ 384 Plate is designed to generate several 3D cell model types, such as organoids, spheroids and microtissues. For the remainder of the document, we will refer to these models as 'spheroids'.

Advantages of Akura™ 384 Spheroid Microplate

1. Convenient scaffold-free formation of spheroids via cellular self-assembly in ultra-low attachment (ULA-treated) plates.
2. SureXchange™ tapered ledge and culture chamber facilitates easy medium exchange and prevents spheroid loss during long-term spheroid growth and analysis.
3. 1 mm diameter flat bottom observation chamber enables simple spheroid localization, observation, and ROI identification.
4. The continuous, 125 µm Polystyrene bottom results in enhanced imaging quality and the black-walled body eliminates fluorescent crosstalk between wells.
5. Akura™ 384 Plate is compatible with state-of-the-art imaging and automated liquid handling systems enabling HTS applications.

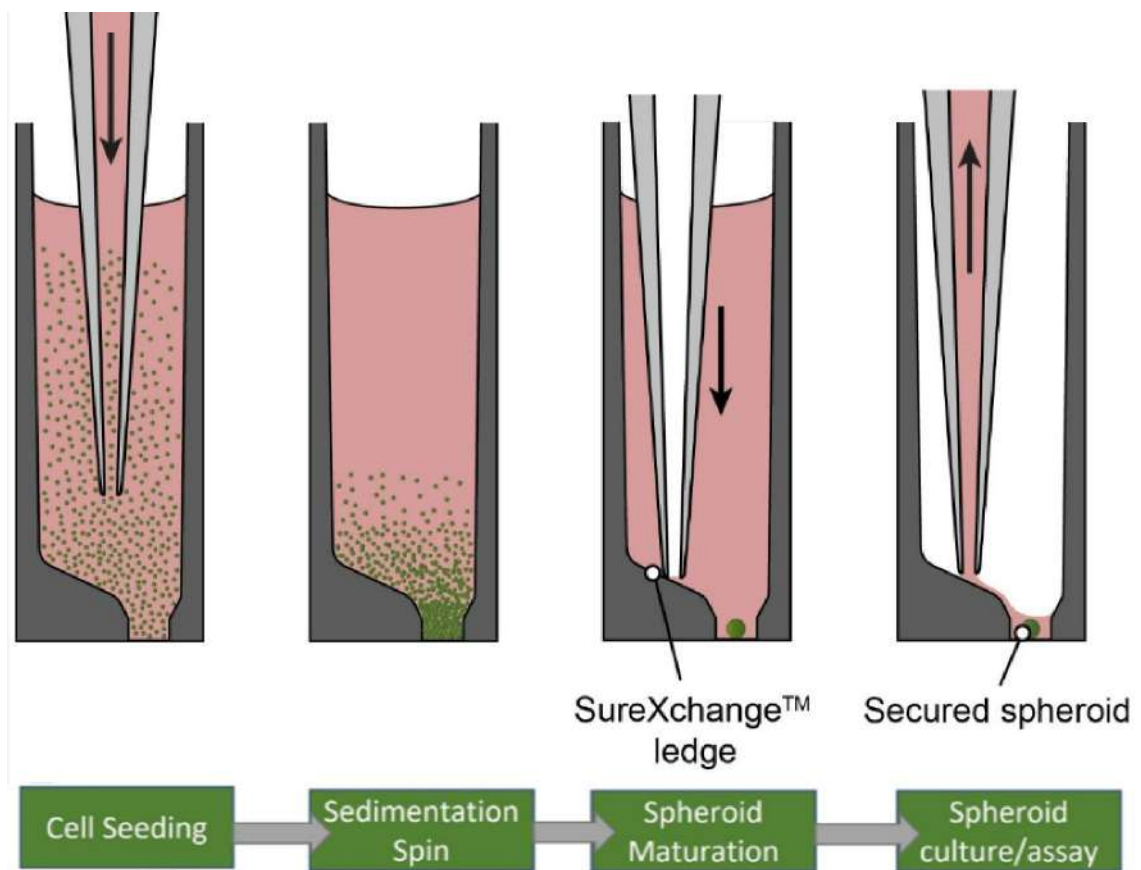

Figure 1: Spheroid formation in the Akura™ 384 Plate begins with initial seeding of cells in suspension, followed by a brief spin to concentrate cells. Following spheroid maturation, the SureXchange™ ledge of the tapered well facilitates medium exchange and compound dosing without disturbing or losing the spheroid.

The Akura™ 384 Spheroid Microplate

The Akura™ 384 Spheroid Microplate is a special ULA-coated 384-well microtiter plate. It is designed to accommodate the production of 3D spheroids for convenient long-term cultivation and analysis. Akura™ 384 tapered wells feature a SureXchange™ ledge to prevent inadvertent spheroid aspiration and disruption during medium exchange and compound dosing (Fig. 1). Spheroids are positioned in a 1.0 mm observation chamber at the bottom of each well, which enables automated imaging processes (Fig. 2). Biochemical assays as well as optical analytical methods such as inverse bright field and fluorescence microscopy can be performed.

Spheroid production with Akura™ 384 Plates is simple and recommended for cell types that are known to readily form spheroids in ULA conditions, or as a first step in characterizing the spheroid-forming capacity of a particular cell type of interest. A cell suspension is delivered to the bottom

plate using a multi-channel pipette or a robotic liquid handler. Following brief centrifugation to concentrate cells near the bottom of the tapered chamber, spheroids begin forming by gravity-assisted self-assembly. Spheroid maturation typically occurs within 2-5 days of seeding depending on the cell type and culture conditions (Fig. 1).

Figure 2: Brightfield image of 3D InSight™ Human Liver Microtissue. Picture acquired with a Zeiss Axiovert 25 inverted microscope, 5x objective, Canon® PowerShot digital camera, zoom 8.9x.

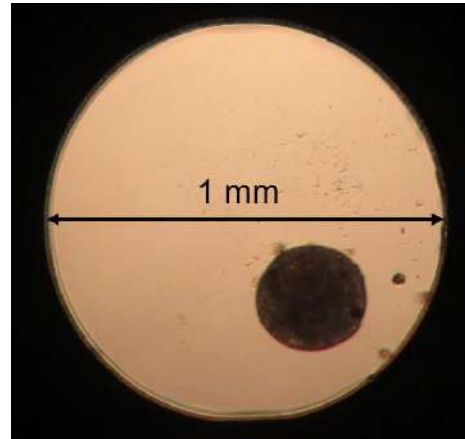

Akura™ 384 Spheroid Microplate Design

Akura™ 384 Plates have a unique plate and well design (Figure 3A, B) that protects spheroids from accidental aspiration during routine pipetting tasks and ensures accurate dilutions for compound dosing. It is important to understand how to orient the plate and pipette tips to take advantage of the special features of the plate (Figure 3A, B, C).

A. Akura™ 384 Plate and spheroid position in wells

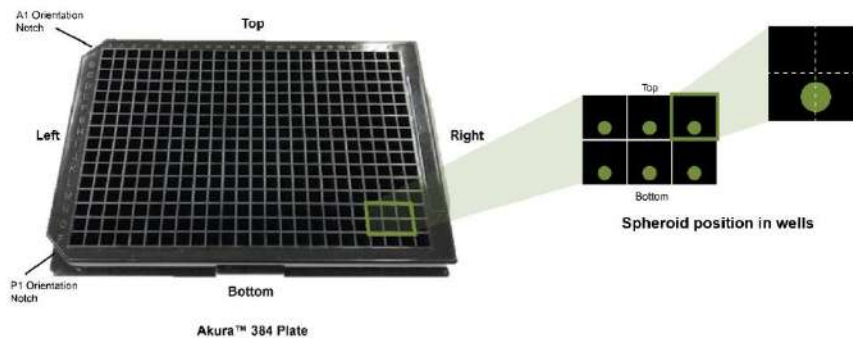

B. Well design with SureXchange ledge

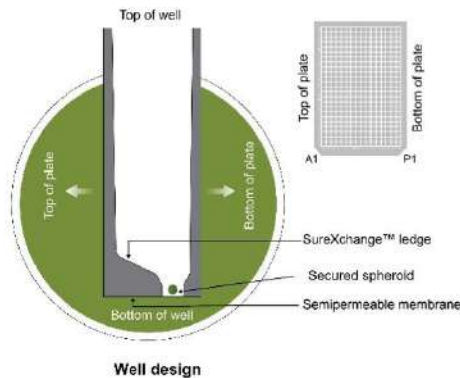

C. Safe media withdrawal and accurate compound dosing

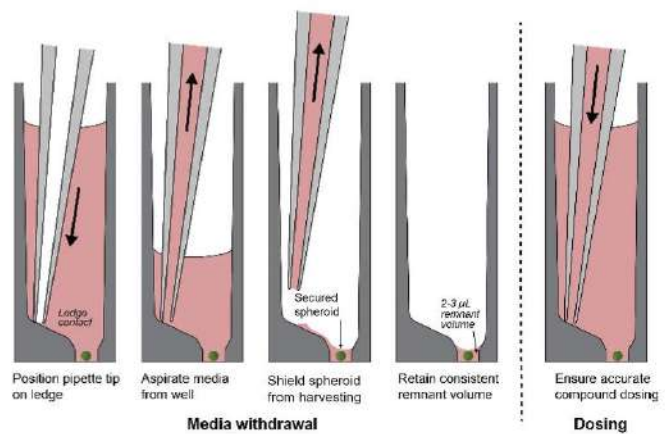

Figure 3: A. The Akura™ 384 Plate layout is 16 rows by 24 columns with well markings on the left side from top to bottom (A-P) and on the top from left to right (1-24). Plate orientation notches are located at the A1 and P1 well corners. Spheroids are secured at the bottom of the plate wells, and positioned in the horizontal center, and lower vertical half of the well. B. A side view of the well design illustrates the position of the SureXchange™ ledge that protects the spheroid from accidental harvesting. C. The well design facilitates safe media withdrawal, consistent media remnant volume, and accurate compound dosing. (Pipette angle for right-handed plate orientation shown.)

Plate orientation for manual pipetting tasks

Important: The off-set positions of the SureXchange™ ledge and spheroid cavity necessitate correct orientation of the plate and positioning of pipette tips. To avoid pipetting errors, use the same plate orientation for the duration of a given experiment or assay.

For right-handed operators: Turn the Akura™ 384 Plate 90° to the left, so that the A1 orientation notch is on left-hand side and the P1 orientation notch is on the right-hand side (Figure 4A).

For left-handed operators: Turn the Akura™ 384 Plate 90° to the right, so that the A1 orientation notch is on right-hand side and the P1 orientation notch is on the left-hand side (Figure 4B).

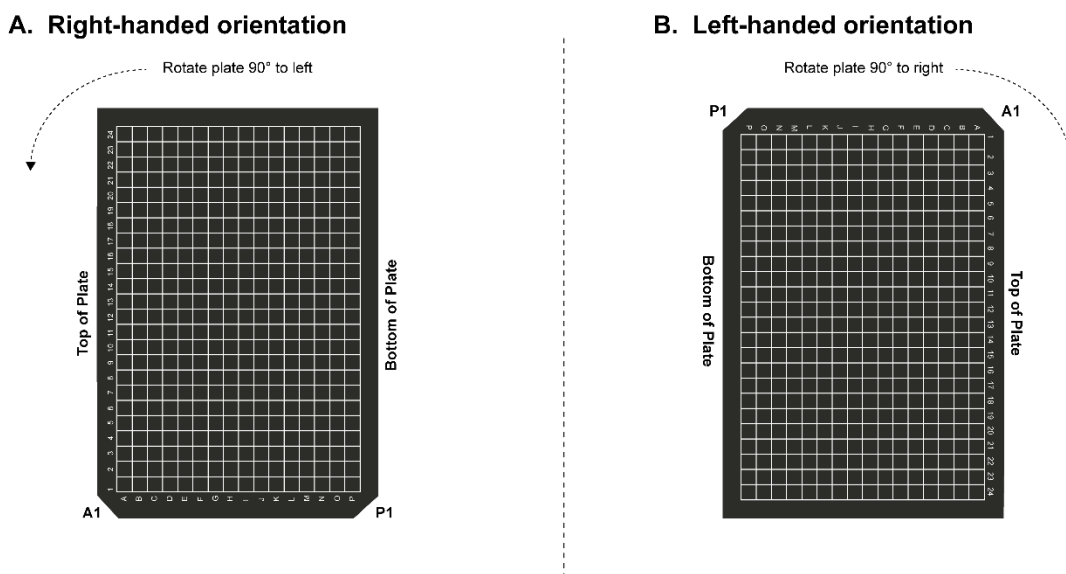

Figure 4: Recommended plate orientation for A. right-handed operators and B. left-handed operators.

For pipetting tasks that do not involve harvesting the spheroid for downstream processing and analysis, always orient the plate (based on operator preference), then position the pipette tip against the well wall, at an angle toward the top of the plate, and slide it downward until the SureXchange™ ledge is felt (Figure 3C).

Generating 3D Spheroids

Generating 3D spheroids in the Akura™ 384 Spheroid Microplate is a straightforward process, but one that must be optimized for each cell type. Cell type, growth medium, and intended downstream applications will impact the starting density and desired culture volume. Optimization is recommended for each cell type and application.

Additional Materials Required

1. Mammalian cells (primary or cell line) of interest
2. Your specific maintenance medium
3. Inverted microscope with a 5x/10x objective
4. Cell counter, e.g. Neubauer chamber
5. Single channel pipette, multichannel pipette (e.g., INTEGRA 8-channel, cat. no. 4626 or INTEGRA 12-channel, cat. no. 4633), or INTEGRA Biosciences VIAFLO 96/384 system (recommended); see sections on Media exchange and spheroid collection and transfer for additional details on which pipettes are appropriate for specific tasks
6. Medium reservoir for multichannel pipettes
7. Microplate centrifuge
8. Humidified 5% CO₂ incubator 37°C

Preparation

1. Prior to seeding, pre-warm the cell maintenance medium to 37°C.
2. Wipe the Akura™ 384 Plate bag with 70% EtOH before opening.
3. Carefully open the bag under sterile working conditions e.g. inside a biosafety cabinet and take out the Akura™ 384 Plate assembly.

Pre-wetting

IMPORTANT

- Pre-wetting the wells of the Akura™ 384 Plate according to the procedure below is highly recommended in order to prevent inclusion of air bubbles.
 - Perform all following steps under sterile conditions.
1. Add 50 µl of PBS to each well by placing the tip near to, but not touching the bottom of the well. It is recommended to use a multichannel pipette (8- or 12-channel).

2. Centrifuge the Akura™ Plate for 2 minutes at 250 RCF and incubate it in a humidified CO₂ incubator for at least 1 day.
3. Before cell seeding take the Akura™ Plate from the incubator, centrifuge the Akura™ Plate for 2 minutes at 250 RCF. Aspirate the pre-wetting solution by placing the tip at the ledge of the upper cavity of the well. Aspirate until the PBS is removed from each well. A small amount of PBS (< 2-3 µl) remains in the bottom of the chamber.

Cell seeding

1. Prepare a single-cell suspension of your preferred cell type or cell mixture, according to your standard protocol.
2. Count the cells using a Neubauer chamber or cell counting instrument to determine the starting cell concentration.
3. Prepare the final cell suspension for seeding, using a final volume per well of 50 µl. Recommended cell concentrations: For long-term growth profiling start with low cell numbers (250–500 cells per well). If non-proliferating cells or rapid production of larger spheroids/organoids are required, start with 2500–25,000 cells per 50 µl.

IMPORTANT – To generate spheroids with uniform size and cell composition, it is essential to assure a homogeneous distribution of the cell suspension by gently pipetting up and down prior to seeding into the Akura™ 384 Plate.

4. Gently (≤ 10 µl/sec) add 50 µl of the cell suspension to the Akura™ 384 Plate by placing the pipette tips far into the wells (avoid touching the well bottom)

Cell sedimentation and spheroid maturation

Following seeding, it is recommended (but optional) to briefly centrifuge the plate to remove any air bubbles, and to force cells to the bottom of the well in order to promote aggregation and spheroid formation.

1. Place the lid on the Akura™ 384 Plate and spin in a microplate centrifuge for 2 minutes at 250 RCF.
2. Following centrifugation, remove the plate and incubate the plate in a humidified 5% CO₂ incubator at 37°C for 2-5 days, checking daily to observe spheroid maturation and exchanging medium as necessary.
3. Tilt the plate in the incubator to approximately 30° by leaning it against another plate or use Akura™ Tilting Stand (InSphero, CS-AG11) to improve the maturation process.

Medium Exchange in Akura™ 384 Spheroid Microplates

Medium exchange with multi-channel electronic pipettes

Cultivating spheroids typically requires 2-3 medium exchanges per week. To exchange medium, please follow these steps and review our recommendations (Table 1).

1. Orient the Akura™ 384 Plate based on operator preference (Figure 4A, B).
2. If using an electronic multi-channel pipette (recommended), set it to a slow speed (< 20 µl/sec).
3. Place multi-channel pipette tips at the ledge by slowly sliding down along the inside of the well wall (angled slightly toward the top of the plate) until a subtle resistance can be felt (Figure 3C).
Note: Proper aspiration with a multi-channel pipette is possible only row-wise.
4. Carefully and slowly remove the medium by aspirating an excess of volume (> 50 µl). This will lead to an almost complete removal of the medium, with a consistent residual medium volume of ~2-3 µl.
5. Add 50 µl of pre-warmed medium by placing the pipette tip at the ledge of the plate well (Figure 3C) and gently dispense at a slow pipetting speed. Never allow the pipette tip to touch the bottom of the well as it consists of a 125 µm thin membrane.
6. Optional: For a more thorough medium exchange, repeat steps 3 and 4.

Table 1

Recommendations for culturing spheroids in Akura™ 384 Plates

Material/Process	Recommendation
Culture medium volume	50 µl/well
Medium exchanges	Typically 2-3 times per week
Pipettes	INTEGRA VIAFLO multichannel pipette system, Integra 300 µl pipette tips with filters (Cat. No. 6465)
Aspiration speed	Slow (< 10–20 µl/second)
Dispense speed	Slow (< 10- 20 µl/second)

Semi-automated medium exchange with the INTEGRA VIAFLO 96/384 System

The unique design of the Akura™ 384 Plate enables the use of multi-channel pipetting systems for parallel liquid handling without the risk of spheroid loss. We recommend the INTEGRA VIAFLO 96/384 system as it is a compact, easy-to-use, semi-automated pipette system that can be configured for 384 channels (Figure 5) for increased productivity.

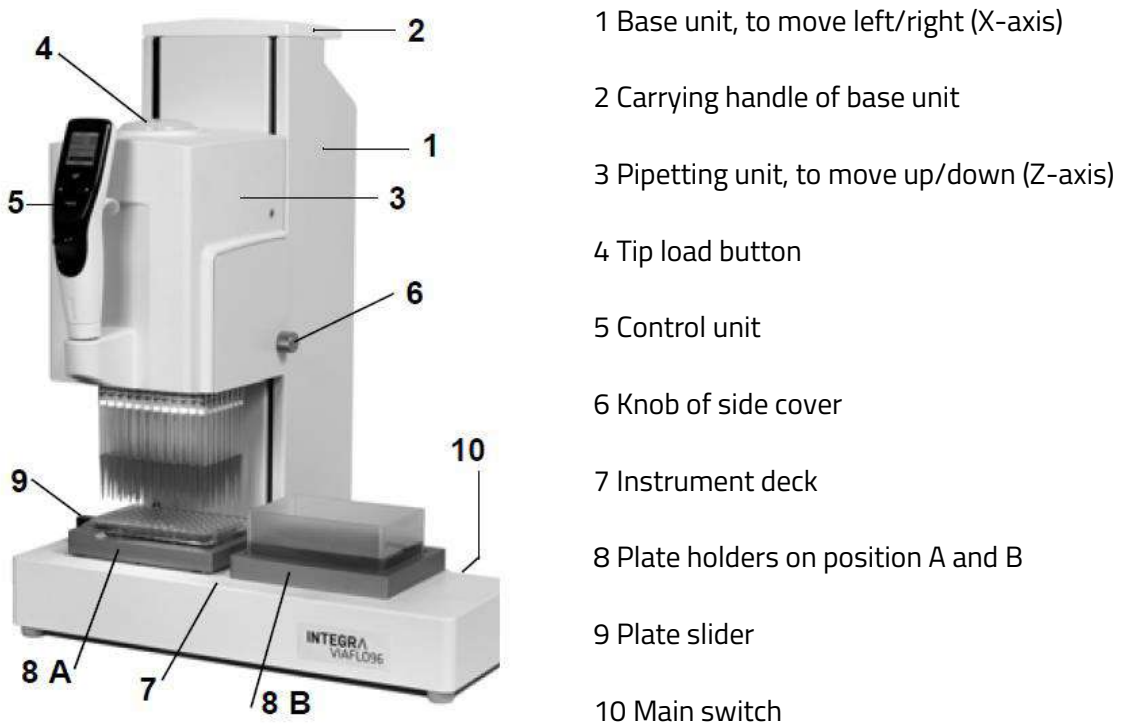

Figure 5: VIAFLO 96/384 Device

The following guidelines are for using the INTEGRA VIAFLO system with Akura™ 384 Plates. Some parameters may vary due to different hardware and software versions and/or different accessories of the system. Please refer to the *INTEGRA VIAFLO 96/384 Operating Instructions* for additional details.

INTEGRA VIAFLOW 96/384 System Configuration:

- VIAFLO 384 (2nd Generation, Part No. 6031)
- 384-channel pipette head, 5-125 µl (Part No. 6132)
- Spring loaded plate holder 8A with slide function (384 offset) (Part No. 6215)
- Standard plate holder for 384 well plate in position 8B (Part No. 6205)
- Grip tips, 125 µl, sterile, with filter (Part No. 6465)

- Reservoirs, 300 ml in tray (Part No. 6327)
- Firmware Base unit: 3.27
- Firmware Control unit: 3.11

Medium exchange is executed in two steps: First, medium is aspirated from one or more plates and discarded or sampled, then fresh medium is dispensed to wells from reservoirs.

Medium aspiration

1. Configure the INTEGRA VIAFLOW System with a 384-pipette head and 125 µl pipette tips (e.g., INTEGRA 125 µl with filters, Cat. No. 6465).
2. Place waste reservoir or plate for samples in position 8B (Figure 5), in the plate holder on the right.
3. Position the Akura™ 384 Plate onto a standard multiwell lid with the opening face down to allow manual positioning of the plate with a slight horizontal offset (1-2 mm) towards the "bottom of the plate" with respect to the tips. Move the plate and lid to position 8A (Figure 5), in the plate holder on the left.
4. Program the pipette for medium aspiration (Table 2).

Table 2

Example medium aspiration pipetting program

Step	Instruction	Notes
1	Tip Align A3	Move pipette head to position 8A above Akura™ 384 Plate.
2	Z-Height pos. 8A, 31.3 mm*	Gently immerse pipette tips into Akura™ 384 Plate wells, until reaching Z-Height (31.3 mm). Displace Akura™ 384 Plate by 1-2 mm toward the plate bottom (Figure 1A). Hold the plate in this position.
3	Aspirate 60 µl, speed 1	Aspirate 60 µl with speed 1.
4	Tip Align B3	Move pipette head to position 8B (right) above wells/reservoir.
5	PURGE, speed 4	Set purge speed and dispense medium.

Note: Z-Height position may vary from instrument to instrument and must be preset prior to pipetting. For orientation, the SureXchange™ ledge (Figure 1B) is located 9.4 mm below the top rim of the well.

Medium dispensing

1. Configure the INTEGRA VIAFLOW with a 384-pipette head and 125 µl pipette tips.

2. Place medium reservoir position 8B (plate holder on right).

Note: Calculate up to 10 ml of extra medium to prevent aspiration of air.

3. Place Akura™ 384 Plate containing spheroids in position 8A (plate holder on left).

Note: Place the Akura™ 384 Plate onto a standard multi-well lid with the opening face down. This allows the plate to be positioned with a slight horizontal offset (1-2 mm) with respect to the tips.

4. Program the pipette for medium dispensing (Table 3, Specifications for: 384-channel pipette head, 125 µl volume pipette tips and a standard multi-well lid as base for Akura™ 384 Plate).

Table 3

Example medium dispensing pipetting program

Step	Instruction	Notes
1	Tip Align B3	Move pipette head to position 8B (right) into reservoir.
2	Aspirate 60 µl, speed 3	Aspirate 60 µl with speed 3 (50 µl plus 10 µl excess volume remaining in the tip).
3	Tip Align A3	Move pipette head to position 8A above Akura™ 384 Plate.
4	Z-Height position 8A, 38.8 mm*	Gently immerse the pipette tips into the wells of the Akura™ 384 Plate, until reaching Z-Height (38.8 mm). Displace Akura™ 384 Plate by 1-2 mm toward the plate bottom to reposition pipette tips along well wall. Hold the plate in this position.
5	Dispense 50 µl, speed 1	Dispense 50 µl into well with speed 1.
6	Tip Align B3	Move pipette head to position 8B (right) above wells/reservoir.
7	PURGE, speed 4	Set purge speed and dispense medium.

Note: Z-Height position may vary from instrument to instrument and must be preset prior to pipetting, depending on calibration. For orientation, the SureXchange™ ledge (Figure 3B) is located 9.4 mm below the top rim of the well.

Analysis and Assays in Akura™ 384 Spheroid Microplate

The Akura™ 384 Plate format is compatible with a broad variety of biochemical methods and allows for spectrometric measurements with a multi-well plate reader or for visual inspection of spheroids by an inverted microscope (similar to the analysis of standard 2D cultures):

Fluorescent/luminescent multi-well plate reader compatibility

Growth changes and profiles in tumor spheroids expressing GFP/RFP can easily be analyzed using fluorescent plate readers, as the signal intensity is stronger than with monolayer cultured cells.

Automated imaging

The Akura™ 384 Plate is ideal for use in automated imaging equipment, such as the SCREEN Cell3iMager, automated microscopes, and imaging systems as the Akura™ 384 Plate features a continuous, 125 µm bottom resulting in enhanced imaging quality. The black-walled body eliminates fluorescent crosstalk between wells and the 1 mm diameter optically clear base of each well will be positioned exactly in the center of the field of view.

High-content imaging compatibility of the Akura™ 384 Plate

The Akura™ 384 Plate is compatible with state-of-the art high-content imaging instruments, such as

- Perkin Elmer: Opera, Operetta
- Yokogawa: CQ1, CellVoyager CV 8000
- Molecular Devices: ImageXpress
- Cytiva (formerly GE Healthcare): InCell

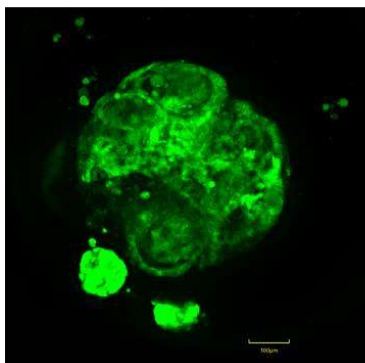
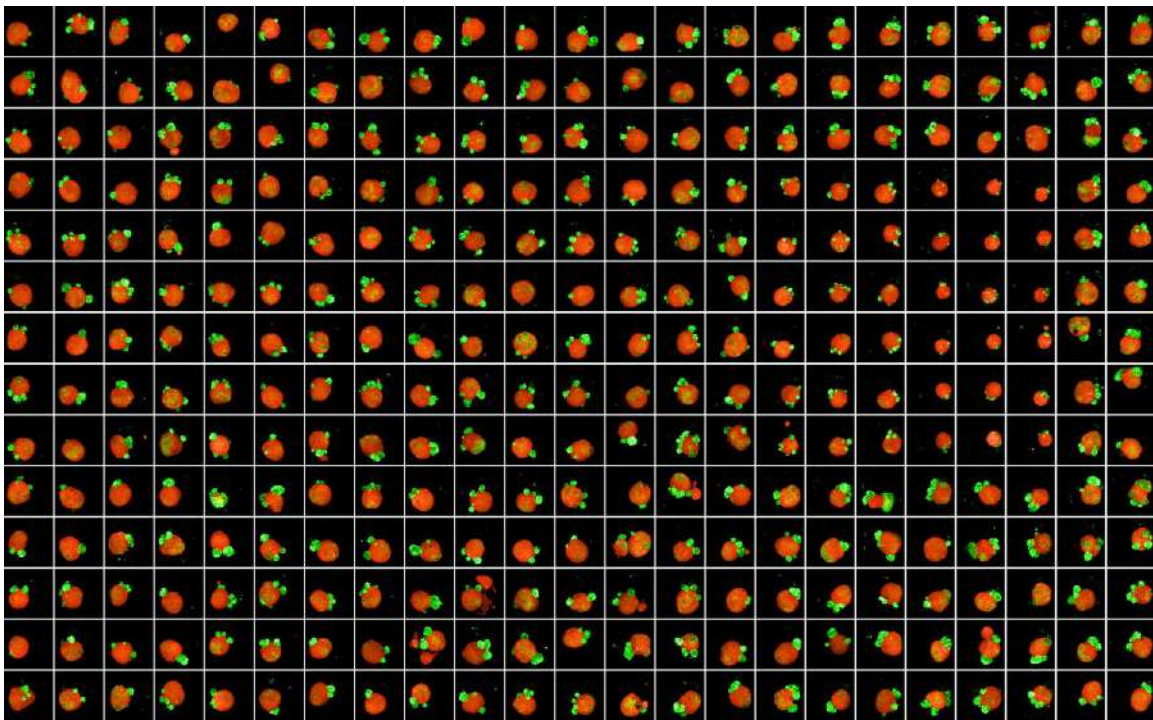

NCI-N87-GFP

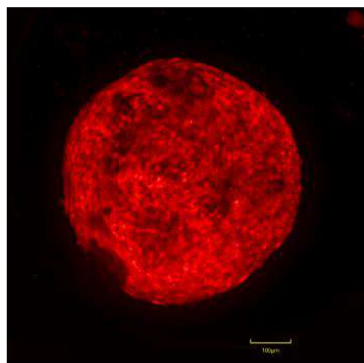

NIH-3T3-RFP

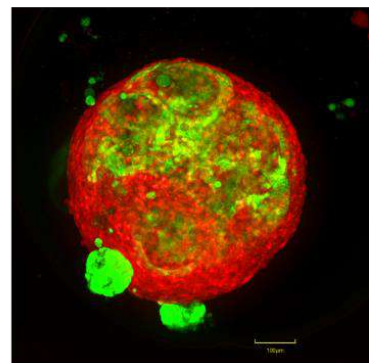

Merge

Figure 6: Images of an NCI-N87/NIH-3T3 co-culture taken with Yokogawa CQ1.

Spheroid Collection and Transfer

The special coating of the Akura™ 384 Plate minimizes the adherence of the spheroids to the bottom of the well. This facilitates collection of spheroids for transfer into another plate format or for further processing, such as embedding for histological analysis. There are several different methods for collecting and transferring spheroids.

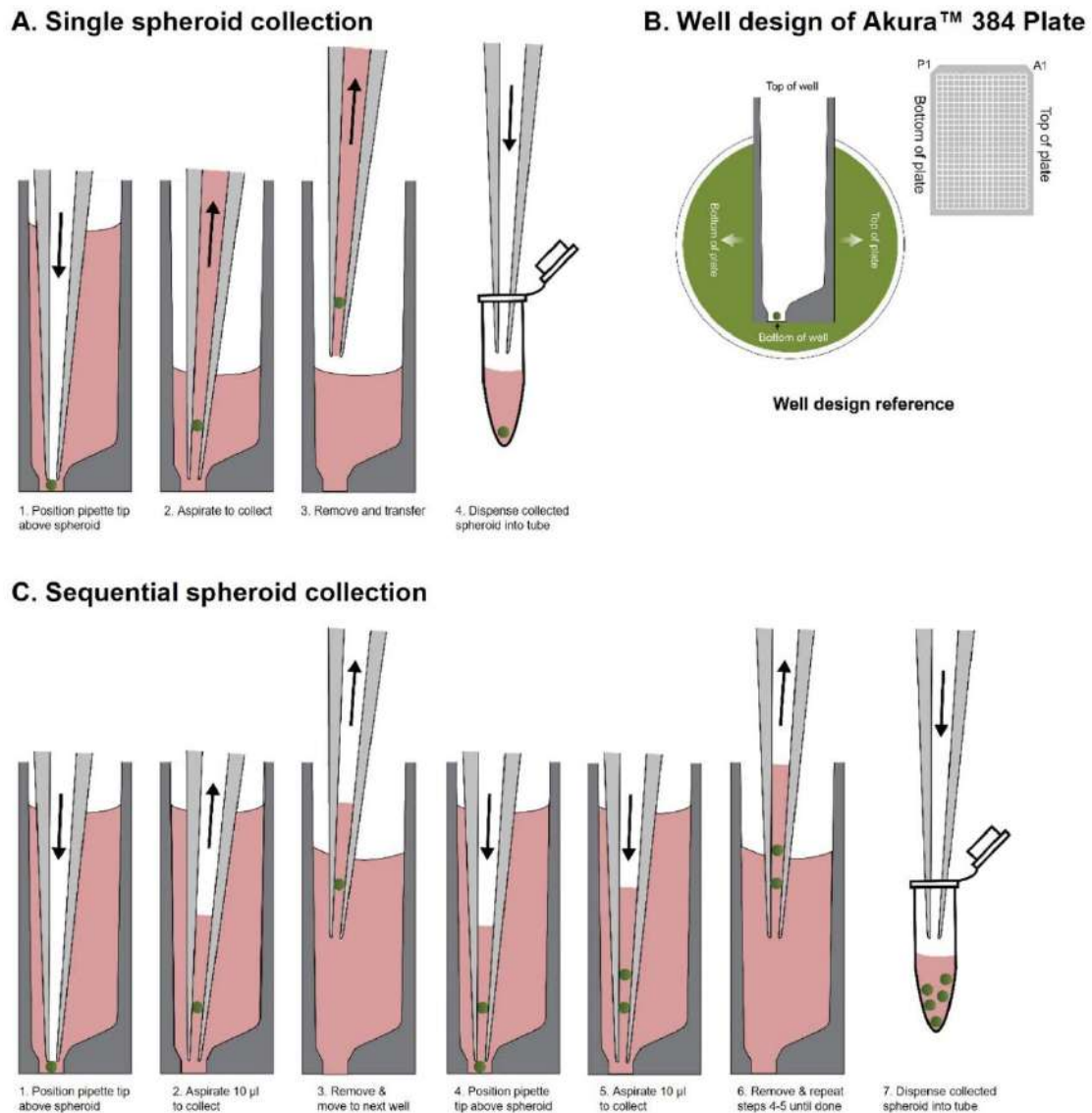

Figure 7: A. Pipette positioning and steps for collecting and transferring a single spheroid from Akura™ 384 Plates for downstream processing. B. Reference of well design in relation to top and bottom of plate. C. Steps for sequential spheroid collection and transfer.

Single spheroid collection and transfer using a single-channel pipette

1. Prewet the tip with at least 50 µl of 100% serum to prevent spheroids from sticking to the inside walls of the tip.
2. Gently immerse the pipette, holding a narrow, elongated 1250 µl tip (e.g., Greiner Bio-One Sapphire, Cat. No. 750 265) along the inside, the bottom wall of the well, until feeling a slight resistance. The pipette tip orifice is now positioned slightly above the spheroid on the well bottom (Figure 7A). Use of this tip guards against accidentally squeezing spheroids during collection because the tip diameter exceeds the size of the well bottom.
3. Collect the spheroid by aspirating 40 µl of medium at medium speed (Figure 7A). Depending on the spheroid and pipette type in use, different volumes, speeds, and repetitions are required to successfully aspirate and eventually transfer the spheroid. Avoid aspiration of air bubbles to prevent spheroid loss in the pipette tip.
4. Gently dispense spheroid into another vessel or plate.

Note: If recipient plate is pre-filled with media, no dispensing step is needed. Immersing the tip into the medium in upright position is sufficient for spheroid to drop by gravity. Wait 30–60 seconds to allow spheroid settle inside the well.

Sequential spheroid collection and transfer using a multi-channel pipette

1. Prewet the tip with at least 130 µl of 100% serum to prevent spheroids from sticking to the inside walls of the tip.
2. Set your multi-channel pipette to “variable/multi aspirate” mode, 8–12 aspiration steps of 10 µl, speed 5–10. Load one 300 µl tip, with or without filters, depending on downstream activity (e.g., sterile: INTEGRA, Cat. No. 4435; unsterile: INTEGRA, Cat. No. 6443).
3. Gently immerse the multi-channel pipette, holding one 300 µl tip, along the inside of the well wall until a slight resistance is felt. This positions the pipette tip orifice slightly above the spheroid on the well bottom (Figure 7C.1).
4. Note: The diameter of the 300 µl tip does not exceed the size of the well bottom, so use caution not squeeze the spheroid or pierce the well bottom accidentally.
5. Collect the spheroid by aspirating 10 µl of medium with speed 5–10 (Figure 7C. 2). Repeat the aspiration step for the same spheroid (to increase collection efficiency) or remove pipette from well (Figure 7C. 3) and continue to the next well/spheroid. Collect additional spheroids by aspirating another 10 µl. Execute all the predefined aspiration steps.
6. Note: The number of aspiration steps may vary depending on the number of spheroids to be collected. Different volumes, speeds, and repetitions may be required to successfully collect different types of spheroids.
7. Gently dispense all collected spheroids into collection tube.

Annex A: Akura™ 384 Spheroid Microplate Specifications

The Akura™ 384 Plate format is compliant with standard microplate definitions as specified by the SLAS Microplate Standards Advisory Committee ANSI SLAS 1-2004 (R2012). The 384 wells are arranged in 16 rows and 24 columns, identified by alphanumeric well markings on the left side from top to bottom (A-P) and on the top from left to right (1-24). Plate orientation notches are located at the A1 and P1 well corners (Figure 8A). Individual wells show a regular wide opening at the top narrowing down into a small, asymmetric cavity at the well bottom, with a flat optically clear base (Figure 8B), designed to accommodate spheroids of up to 1 mm in diameter. Spheroids in wells can be observed using standard imaging equipment (Figure 8C, D). The Akura™ 384 Plate Technical Specifications provides additional details about plate design and dimensions (Figure 9,10,11).

Plate Dimensions:

Plate length:	127.76 mm
Plate width:	85.48 mm
Height of plate:	14.80 mm
Height of well:	11.93 mm
Skirt height:	2.77 mm
Diameter well bottom:	1.00 mm
Thickness well bottom:	0.125 mm
A1 to top offset:	9.89 mm
A1 to side offset:	12.13 mm
Well center to cavity center offset:	0.90 mm
Working volume:	40-50 µl
Well-to-well distance:	4.5 mm

A Akura™ 384 Plate design

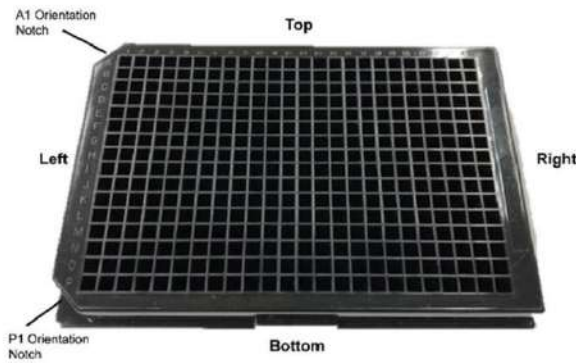

B Well dimensions and spheroid position

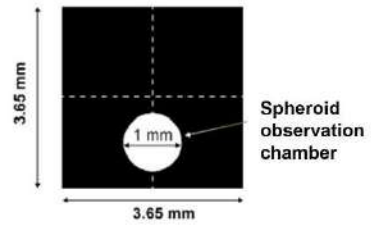

C Imaging scans of spheroids in wells

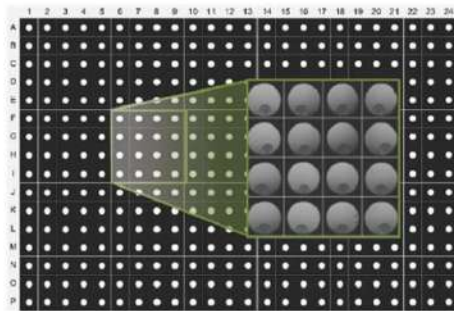

D Spheroid in 1 mm observation chamber

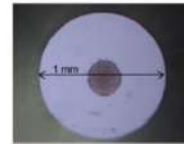

Figure 8: A. Akura™ 384 Plate is clearly marked. B. Overhead view of well dimensions and 1 mm spheroid observation chamber. C. Imaging scan of an Akura™ 384 Plate shows one spheroid per well and the position of each spheroid within the observation chamber. D. Image of a spheroid within the 1 mm spheroid observation chamber.

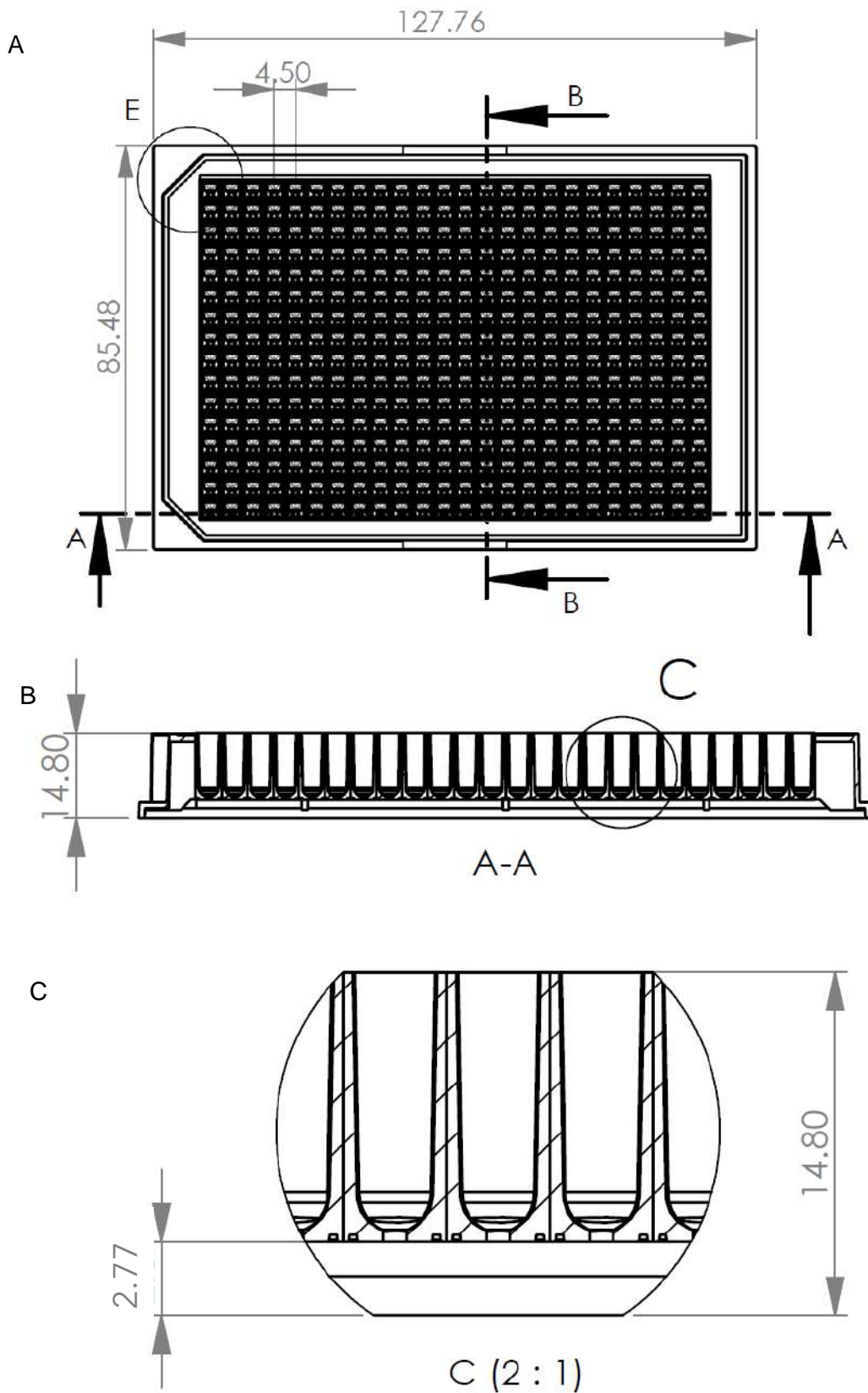

Figure 9: A. Plate layout. B. Row cross section with plate height and C. Skirt height (distance between plate bottom is 2.77mm).

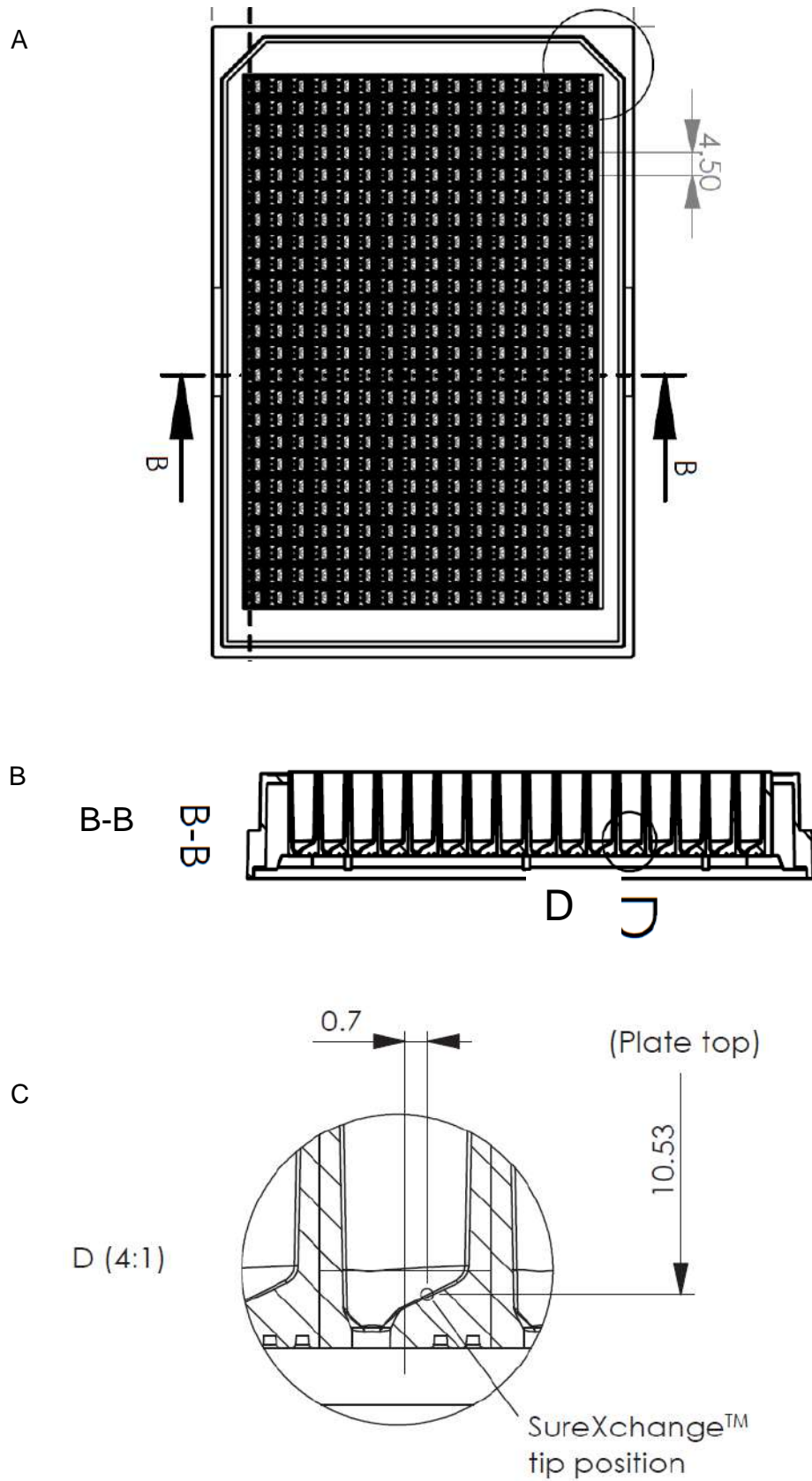

Figure 10: A. Vertically oriented plate layout. B. Row cross section and C. Well cross section.

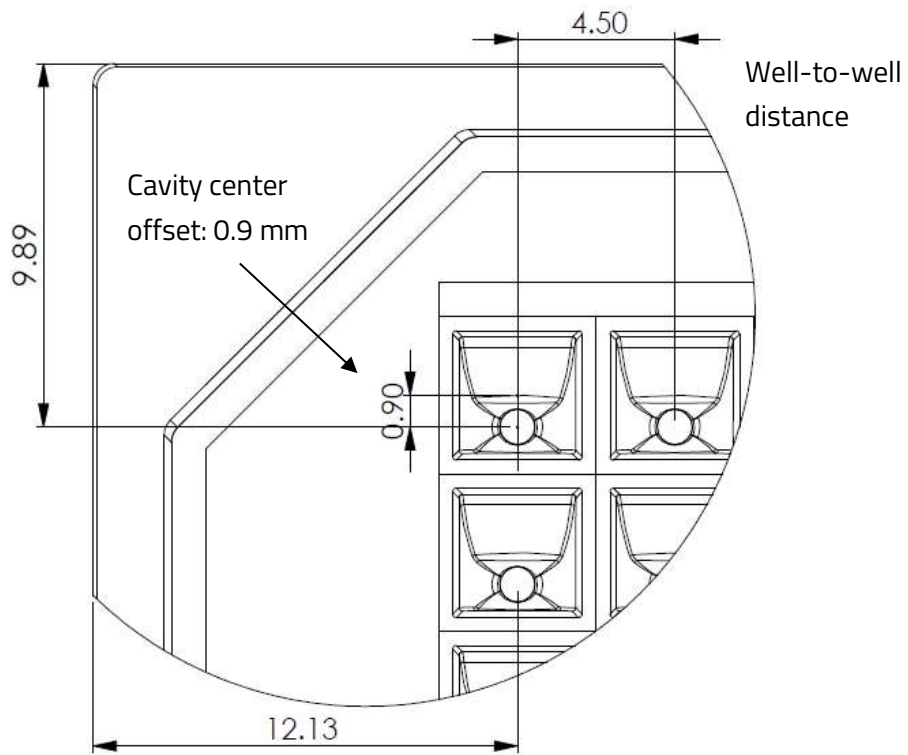

Figure 11: Top-down view showing cavity center offset.

Akura™ 384 Plate restrictions

The skirt height of the Akura™ 384 Plate is 2.77 mm. The skirt height is the distance between the well bottom (the 125 µm membrane) and the plate bottom (Figure 12). This design may restrict certain high NA objectives and immersion objectives to reach the outer wells of the plate.

Plate Skirt Height

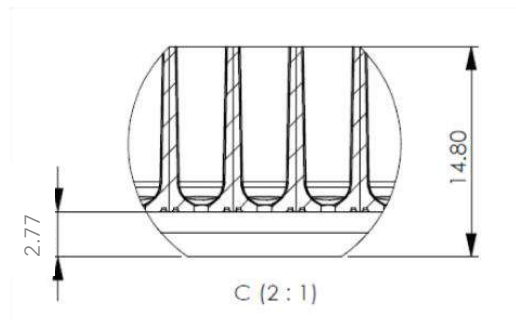

Figure 12: Skirt height of 2.77 mm does not allow high NA and water immersion objectives to be used for outer wells.

Annex B: License Agreement

License Agreement Akura™ 96 Spheroid Microplate, Akura™ 384 Spheroid Microplate and Akura™ PLUS Hanging Drop System

This License Agreement (the „License Agreement“) is a legal agreement between the end user („End User“) and InSphero AG or its subsidiaries („InSphero“) to use the Akura™ 96 Spheroid Microplate, Akura™ 384 Spheroid Microplate and Akura™ PLUS Hanging Drop System („Akura Plates“) covered by patents owned or controlled by InSphero which are provided to you.

1. Warranties: The End User hereby irrevocably warrants to keep and use the Akura Plates in accordance with the restrictions and limitations contained in this License Agreement.
2. Proprietary rights of the Akura Plates may be covered by one or more of the following patents: US 9126199 B2, CA 2737627 C, EP 2342317 B, DK 2342317 T3, ES 2401640 T3, CN 102257123 B, JP 5490803 B2, and other pending patent applications. By entering into this License Agreement, End User acknowledges that the Akura Plates are so covered.
3. Excluded Fields: No permission is granted hereunder for the use of the Akura Plates:
 - a. for selling cell-based products generated using the Akura Plates to third parties;
 - b. for using with human or animal primary pancreatic islets, or islet like cells (e.g. stem cell derived islet like cells);
 - c. for screening or testing of more than 10,000 distinct compounds (high throughput screening);
 - d. in veterinary applications, in diagnostics, *in vivo* use in humans and/or uses related to food products.

Use by the End User Subject to Clause 3 above End User will use the Akura Plates solely for in vitro research in-house for the discovery and development of compounds outside the Excluded Fields by End User. End User will not sell, transfer, disclose or otherwise provide access to the Akura Plates to any third party or entity. End User will not sell, or transfer cell-based products generated using the Akura Plates to any third party or entity.

Annex C: Frequently Asked Questions Regarding the Akura™ 384 Spheroid Microplate

A protocol for production of spheroids in the Akura™ 384 Plate is provided in the product manual. Below are answers to some frequently asked questions to help get you started.

Q: What is the difference between Akura™ 384 Spheroid Microplate and the Akura™ 384 ImagePro Plate?

A: Both Akura™ 384 Plates have black walls to minimize cross-talk and a unique well design for near-complete medium exchange without spheroid loss.

The Akura™ 384 ImagePro has a flat, ultrathin, 25 µm gas-permeable membrane made of FEP (fluorinated ethylene propylene) to minimize RI mismatch and it is compatible with high NA objectives.

The Akura™ 384 Spheroid Microplate has a 125 µm thin Polystyrene membrane. The plate is especially suited for high throughput applications, lytic and biochemical assays, and basic confocal imaging endpoints.

If you require a high-resolution, high-content imaging endpoint, we recommend the Akura™ 384 ImagePro Plate.

Q: Why do you recommend pre-wetting of the wells prior to spheroid seeding?

A: Pre-wetting the wells of the Akura™ 384 Plate is recommended prior seeding to prevent inclusion of air-bubbles. For pre-wetting, apply 50 µl of PBS to each well by placing the tips near to, but not touching the bottom of the well.

Centrifuge the Akura™ Plate for 2 minutes at 250 RCF and incubate it in a humidified CO₂ incubator for at least 1 day. Before cell seeding take the Akura™ Plate from the incubator, centrifuge the Akura™ Plate for 2 minutes at 250 RCF. Aspirate the PBS by placing the tip at the ledge of the upper cavity of the well. Aspirate until the PBS is removed from each well. A small amount of PBS (< 2-3 µl) remains in the bottom of the chamber.

Q: Could you recommend a cell concentration for my cell suspension for the generating of spheroids?

A: For long-term growth profiling, we recommend starting with low cell numbers (250 – 500 cells per well of 50 µl). If use of non-proliferating cells or rapid production of larger spheroids are required, start with higher numbers (from 2500+ cells per 50 µl). Generally, we recommend trying different concentrations for defining your optimal range when using new cell types.

Q: What is the optimal volume per well in the Akura™ 384 Plate?

A: To achieve optimal conditions, gently deliver 50 µl (pipetting speed < 10 µl/sec) of cell suspension into each well of the Akura™ 384 Plate by placing the pipette tips far into the wells (avoid touching the well bottom).

Important – To obtain spheroids with uniform size and cell composition it is essential to assure a homogeneous distribution of the cells by gently pipetting up and down prior to seeding into the Akura™ 384 Plate.

Q: Why do you recommend centrifuging the Akura™ 384 Plate after cell seeding?

A: We recommend to briefly centrifuge the plate after cell seeding to remove any air bubbles and to force the cells to the bottom of the well to promote cell-aggregation and spheroid formation.

For that, place the lid on the plate and spin in a microplate centrifuge for 2 minutes at 250 RCF. Afterwards, incubate the plate in a humidified CO₂ incubator at 37 °C for 2-5 days.

Q: How do I exchange the medium in the Akura™ 384 Plate without disturbing or losing the spheroids?

A: To prevent spheroid loss during the exchange of media, place multi-channel pipette tips at the ledge by slowly sliding down along the inside of the well wall (angled slightly toward the top of the plate) until a subtle resistance can be felt.

Note: Proper aspiration with a multi-channel pipette is possible only row-wise. Carefully and slowly remove the medium by aspirating an excess of volume (> 50 µl). This will lead to an almost complete removal of the medium, with a consistent residual medium volume.

Add 50 µl of pre-warmed medium by placing the pipette tip at the ledge of the plate well and gently dispense at a slow pipetting speed. Never allow the pipette tip to touch the bottom of the well as it consists of a 125 µm thin membrane.

Important - when using automated liquid handling devices, an off-center alignment of the vertical pipette tip will achieve the same effect.

Q: What is the best way to prevent evaporation in the outer wells of my plates?

A: Evaporation in the outer (perimeter) rows of wells is a phenomenon common to most low-volume culture platforms, and thus requires careful attention to maintaining proper humidity control. If not controlled, pronounced evaporation can result in concentration or precipitation of media components (serum, salt) that can impact spheroid formation or health, and can alter the effective concentration of a compound/additive in the medium over the course of a long-term

experiment. To provide maximum humidity control when using the Akura™ Plates, we recommend the following:

1. Use an incubator with good humidity control (>95% of rel. humidity), and exercise best practice in maintaining and minimizing loss of humidity (e.g., minimize incubator door opening and closing).
2. For culture in the Akura™ 384 Plate, at least 40-50 µl of medium in each well is recommended. Medium exchange frequency can also be increased to every other day or daily if conditions dictate.
3. We recommend the use of the InSphero Incubox™ (CS-AH11) (Figure 13) to reduce edge effects when performing long-term culture with low-frequency medium exchange. The InSphero Incubox™ is available on shop.insphero.com.



Figure 13: InSphero Incubox™



InSphero AG
Schlieren, Switzerland

InSphero Inc.
Brunswick, ME, USA

If you have more questions, please refer to
the [FAQs section on shop.insphero.com](#)

Sign up for latest news and updates at
insphero.com/newsletter

Follow us on [LinkedIn](#) and [Twitter](#)

InSphero is ISO 9001:2015 certified

All rights reserved, © 2021 InSphero AG.
3D InSight, Akura, InFloat and Incubox
trademarks of InSphero AG. For life
science research only. Not for use in
diagnostic procedures.